

Check valve hydraulically pilot operated

RE 21468/07.05
Replaces: 02.03

1/8

Types SV and SL

Nominal sizes 10 to 32
Component series 4X
Maximum operating pressure 315 bar
Maximum flow 550 l/min



Overview of contents

Contents	Page
Features	1
Ordering details	2
Preferred types	2
Symbols	2
Function, section	3
Technical data	4
Characteristic curves	5, 6
Unit dimensions	7, 8

Features

- For subplate mounting
- Connection location to ISO 5781
- Subplates to data sheet RE 45062 (separate order)
- For threaded connections
- With internal or external pilot oil drain, optional
- With or without decompression feature, optional
- Version with decompression feature for dampened decompression (minimising possible pressure shocks)
- 4 opening pressures, optional

Information on available spare parts:
www.boschrexroth.com/spc

Ordering details

	S					-4X/	*
Internal pilot oil drain	= V						
External pilot oil drain	= L						
Further details in clear text							
Seal material							
NBR seals							
FKM seals							
⚠ Attention!							
The compatibility of the seals and pressure fluid used has to be taken into account!							
Opening pressure							
See $\Delta p-q_v$ -characteristic curves							
A to B,							
Pages 5 and 6							

		Type SV		Type SL	
Connection type	G	P	G	P	
Ordering details					
Nom. size 10	= 10	= 10	= 10	= 10	
Nom. size 16	= 15	—	= 15	—	
Nom. size 20	= 20	= 20	= 20	= 20	
Nom. size 25	= 25	—	= 25	—	
Nom. size 32	= 30	= 30	= 30	= 30	

For subplate mounting	= P
For threaded connections	= G
With decompression feature	= A
Without decompression feature	= B

4X =	Component series 40 to 49 (40 to 49: unchanged installation and connection dimensions)
1 =	
2 =	
3 =	
4 =	

Preferred types

Type SL	Material No.
SL 10 GA1-4X/	R900483370
SL 10 GB1-4X/	R900451135
SL 10 PA1-4X/	R900483371
SL 10 PB1-4X/	R900443419
SL 15 GA1-4X/	R900587553
SL 20 PA1-4X/	R900587559
SL 20 PB1-4X/	R900599586
SL 25 GA1-4X/	R900587555
SL 30 GA1-4X/	R900587556
SL 30 PA1-4X/	R900587560

Type SV	Material No.
SV 10 GA1-4X/	R900483368
SV 10 GB1-4X/	R900453511
SV 10 PA1-4X/	R900483369
SV 10 PB1-4X/	R900467724
SV 15 GA1-4X/	R900587549
SV 20 GA1-4X/	R900587550
SV 20 PA1-4X/	R900587557
SV 25 GA1-4X/	R900587551
SV 30 GA1-4X/	R900587552
SV 30 PA1-4X/	R900587558

Further preferred types and standard units can be found within the EPS (Standard Price List).

Symbols

Version SV (internal pilot oil drain)

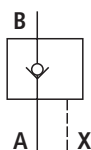

Version SL (external pilot oil drain)

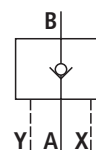

Function, section

The SV and SL valves are hydraulic pilot operated check valves of poppet type design which may be opened to permit flow in the reverse direction.

These valves are used for the isolation of operating circuits which are under pressure, i.e. as a safe guard against the lowering of a load when a line break occurs or against creeping movements of hydraulically locked actuators.

The valve basically comprises of the housing (1), the poppet (2), a compression spring (3), the control spool (4) as well as an optional decompression feature as a ball poppet valve (5).

Type SV...

The valve permits free-flow from A to B. In the reverse direction, the poppet (2) is held firmly on to its seat in addition to the spring force by the system pressure.

By applying pressure to connection X, the control spool (4) is moved to the right. This lifts poppet (2) off its seat. Now the valve also permits free-flow from B to A.

In order to ensure that the valve opens due to the pressure applied to the control spool (4), a certain minimum pilot pressure is required (see page 4).

Types SV.A. and SL.A. (with decompression)

This valve is fitted with an additional decompression feature. When pressure is applied to port X, the control spool (4) is moved to the right. This firstly lifts the ball (5.1) and then the poppet (2) off their seats. The valve now permits flow from B to A.

Because of the decompression feature there is a dampened decompression of the pressurised fluid. Due to this possible pressure shocks are avoided.

Type SL...

The function of this valve corresponds to that of the type SV. The difference is the external Y connection. Here, the annular area of the control spool (4) is separated from the port A. Pressure present in port A only acts on area A_4 (9) of the control spool (4).

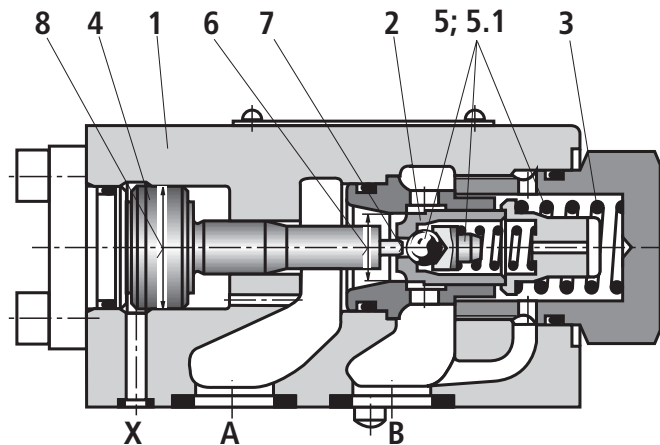

Type SV..PA.-4X/... (without pilot oil drain, with decompression)

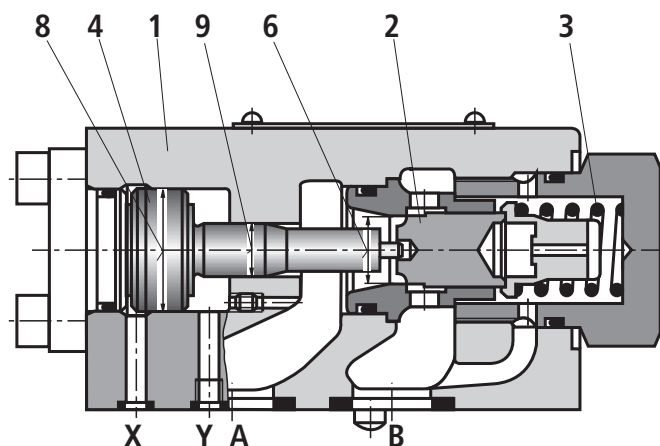

Type SL..PB.-4X/... (with pilot oil drain, without decompression)

- 6 Area A_1
- 7 Area A_2
- 8 Area A_3
- 9 Area A_4

Technical data (for applications outside these parameters, please consult us!)

General							
Nominal sizes			NS10	NS16	NS20	NS25	NS32
Weight	– Subplate mounting	kg	1.8		4.7		7.8
	– Threaded connections	kg	2.1	5.4	5.4	10	10
Installation		Optional					
Ambient temperature range		°C	–30 to +80 (NBR seals) –20 to +80 (FKM seals)				
Hydraulic							
Maximum operating pressure		bar	315				
Maximum flow		l/min	See characteristic curves, pages 5 and 6				
Control pressure		bar	5 to 315				
Pressure fluid		Mineral oil (HL, HLP) to DIN 51524 ¹⁾ ; fast bio-degradable pressure fluids to VDMA 24568 (also see RE 90221); HETG (rape seed oil) ¹⁾ ; HEPG (polyglycoles) ²⁾ ; HEES (synthetic ester) ²⁾ ; other pressure fluids on request					
Pressure fluid temperature range		°C	–30 to +80 (NBR seals) –20 to +80 (FKM seals)				
Viscosity range		mm ² /s	2.8 to 500				
Maximum permissible degree of contamination of the pressure fluid. Cleanliness class ISO 4406 (c)		Class 20/18/15 ³⁾					
Flow direction		Free-flow from A to B, from B to A when opened					
Control volume	– Port X	cm ³	2.5	10.8	10.8	19.27	19.27
	– Port Y (only type SL)	cm ³	2.0	9.6	9.6	17.5	17.5
Control areas (areas according to sectional drawing, see page 3)	– Area A ₁	cm ²	1.33	3.46	3.46	5.72	5.72
	– Area A ₂	cm ²	0.33	0.7	0.7	1.33	1.33
	– Area A ₃	cm ²	3.8	10.17	10.17	16.61	16.61
	– Area A ₄	cm ²	0.79	1.13	1.13	1.54	1.54

¹⁾ Suitable for NBR and FKM seals

²⁾ Only suitable for FKM seals

³⁾ The cleanliness class stated for the components must be adhered too in hydraulic systems. Effective filtration prevents faults from occurring and at the same time increases the component service life.

For the selection of filters see catalogue sheets RE 50070, RE 50076, RE 50081, RE 50086 and RE 50088.

Characteristic curves: subplate mounting (measured with HLP46, $\vartheta_{oil} = 40\text{ °C} \pm 5\text{ °C}$)

Δp - q_V -characteristic curves

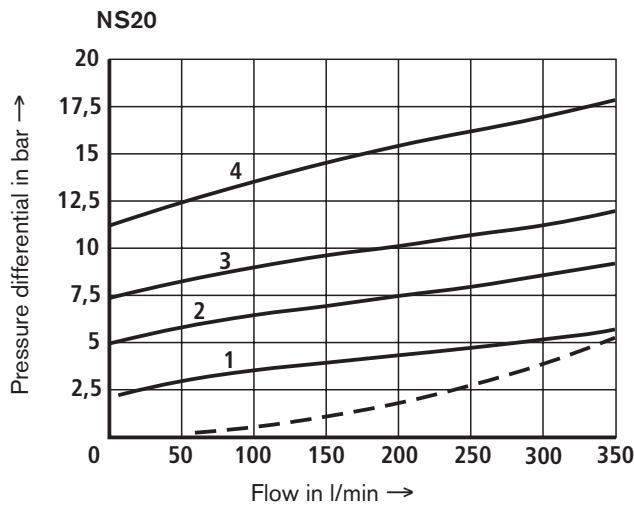
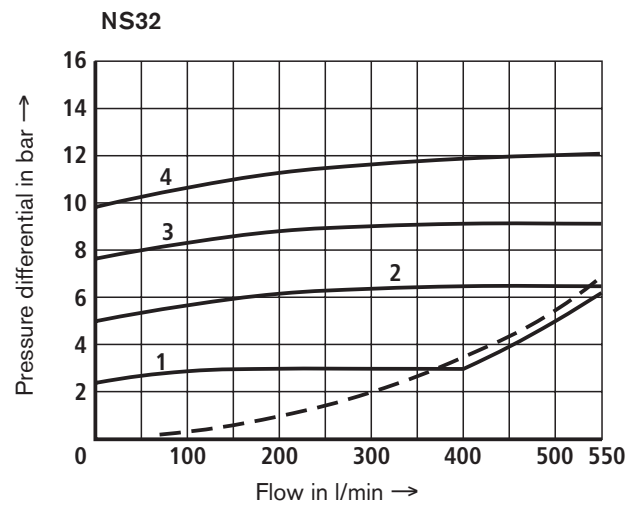
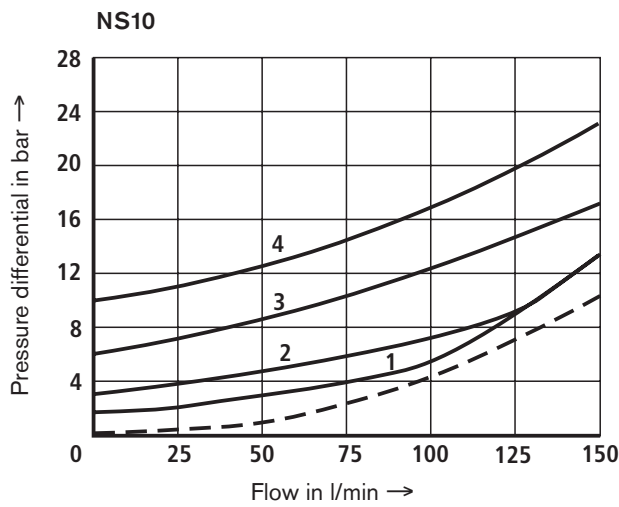

— A to B - - - B to A

Opening pressure in bar

	NS10	NS20	NS32
1	1.5	2.5	2.5
2	3	5	5
3	6	7.5	8
4	10	10	10

Control pressure-load pressure-characteristic curves

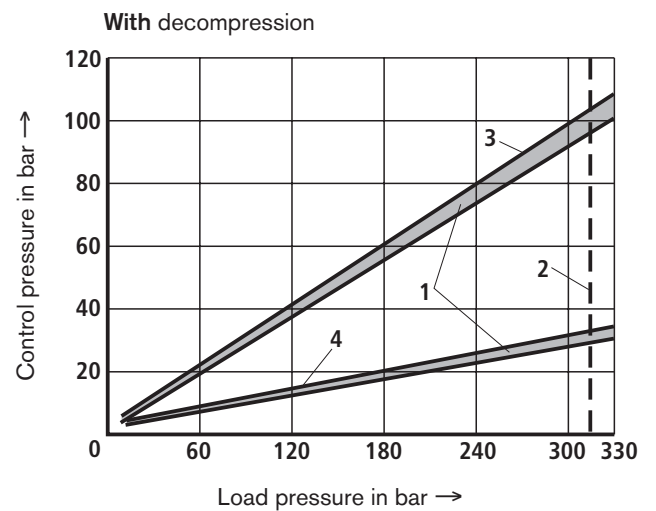
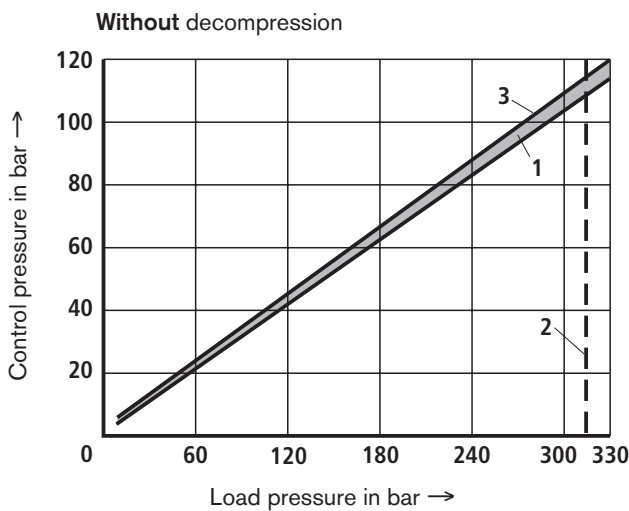

1 Scatter range

2 Limiting value

3 Valve poppet

4 Decompression

Characteristic curves: threaded connections (measured with HLP46, $\vartheta_{oil} = 40 \text{ }^\circ\text{C} \pm 5 \text{ }^\circ\text{C}$)

Δp - q_V -characteristic curves

NS10

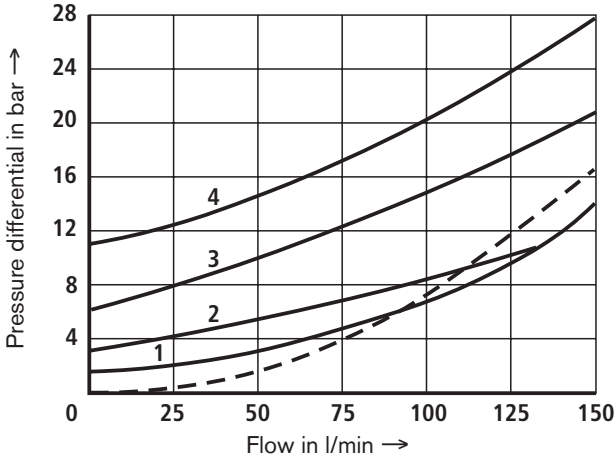

NS25 and 32

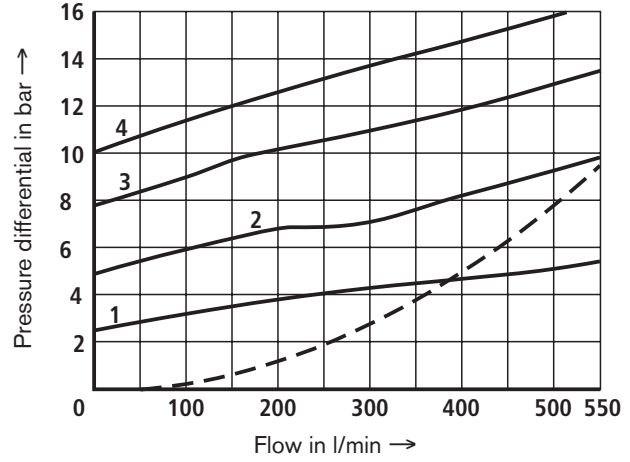

NS16 and 20

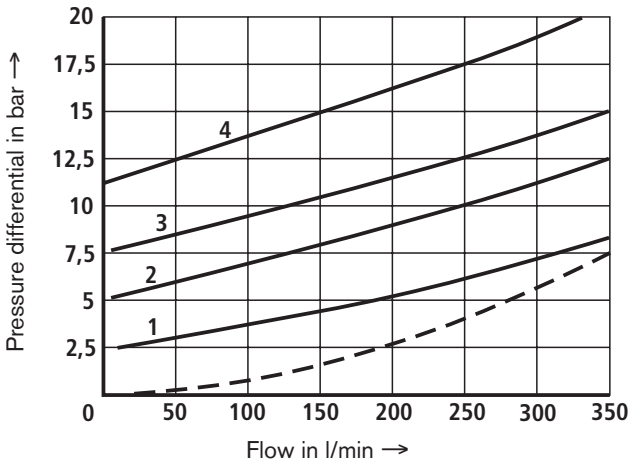

— A to B - - - B to A

Opening pressure in bar

	NS10	NS16 and 20	NS25 and 32
1	1.5	2.5	2.5
2	3	5	5
3	6	7.5	8
4	10	10	10

Control pressure-load pressure-characteristic curves

Without decompression

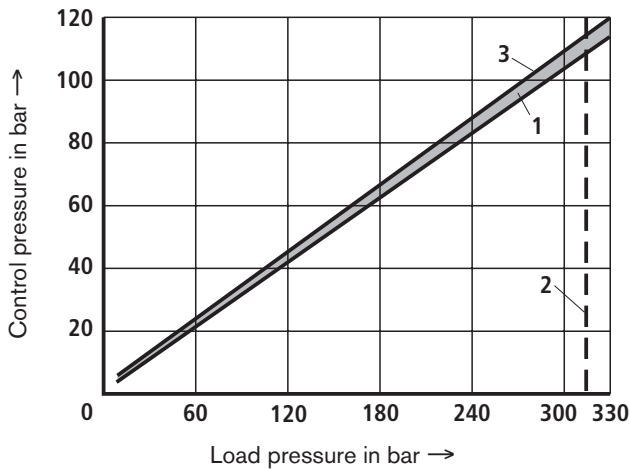

With decompression

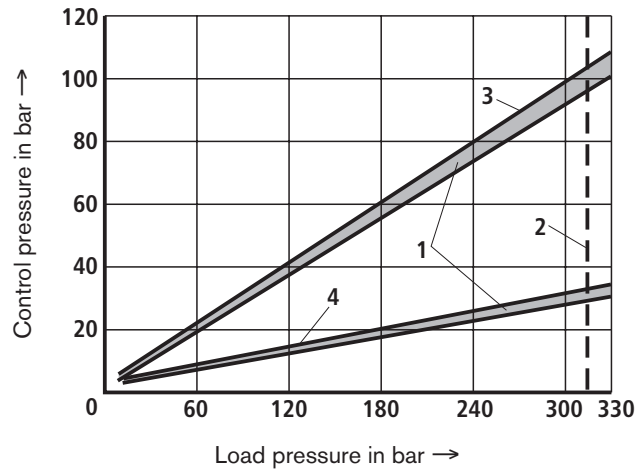

1 Scatter range

2 Limiting value

3 Valve poppet

4 Decompression

Unit dimensions: subplate mounting (nominal dimensions in mm)

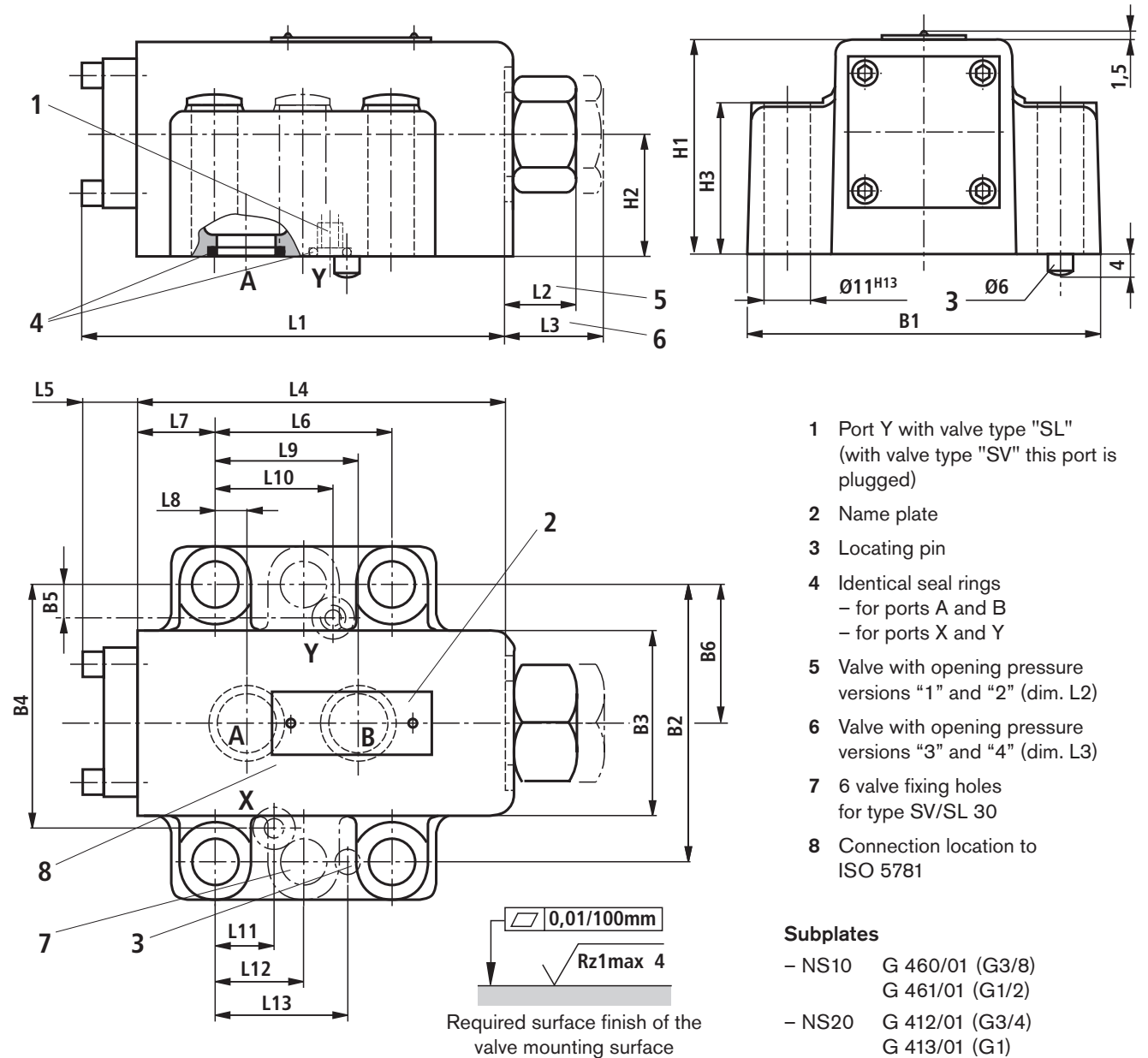

- 1 Port Y with valve type "SL" (with valve type "SV" this port is plugged)
- 2 Name plate
- 3 Locating pin
- 4 Identical seal rings – for ports A and B – for ports X and Y
- 5 Valve with opening pressure versions "1" and "2" (dim. L2)
- 6 Valve with opening pressure versions "3" and "4" (dim. L3)
- 7 6 valve fixing holes for type SV/SL 30
- 8 Connection location to ISO 5781

Subplates

- NS10 G 460/01 (G3/8)
G 461/01 (G1/2)
 - NS20 G 412/01 (G3/4)
G 413/01 (G1)
 - NS32 G 414/01 (G1 1/4)
G 415/01 (G1 1/2)
- to data sheet RE 45062 (separate order)

Valve fixing screws

- (separate order)
- NS10
4 off ISO 4762 - M10 x 50 - 10.9
 - NS20
4 off ISO 4762 - M10 x 70 - 10.9
 - NS32
6 off ISO 4762 - M10 x 85 - 10.9
- (friction value $\mu_{ges} = 0.14$);
Tightening torque $M_A = 75 \text{ Nm} \pm 10\%$
(with changed surfaces please adapt)

Type	NS	L1	L2	L3	L4	L5	L6	L7	L8	L9	L10	L11
SV	10	100,8	15,5	15,5	87,8	13	42,9	18,5	7,2	35,8	–	21,5
	20	135	17,7	47,7	117	18	60,3	27,5	11,1	49,2	–	20,6
	32	156,1	36,1	46,1	134	22,1	84,2	39	16,7	67,5	–	24,6
SL	10	100,8	15,5	15,5	87,8	13	42,9	18,5	7,2	35,8	21,5	21,5
	20	135	17,7	47,7	117	18	60,3	27,5	11,1	49,2	39,5	20,6
	32	156,1	36,1	46,1	134	22,1	84,2	39	16,7	67,5	59,5	24,6

Type	NS	L12	L13	B1	B2	B3	B4	B5	H1	H2	H3	B6
SV	10	–	31,8	84	66,7	44	58,8	–	51	29	36	33,3
	20	–	44,5	100	79,4	61	73	–	70	37	55	39,7
	32	42,1	62,7	118	96,8	75	92,8	–	85	42,5	70	48,4
SL	10	–	31,8	84	66,7	44	58,8	7,9	51	29	36	33,3
	20	–	44,5	100	79,4	61	73	6,4	70	37	55	39,7
	32	42,1	62,7	118	96,8	75	92,8	3,8	85	42,5	70	48,4

Unit dimensions: threaded connections (nominal dimensions in mm)

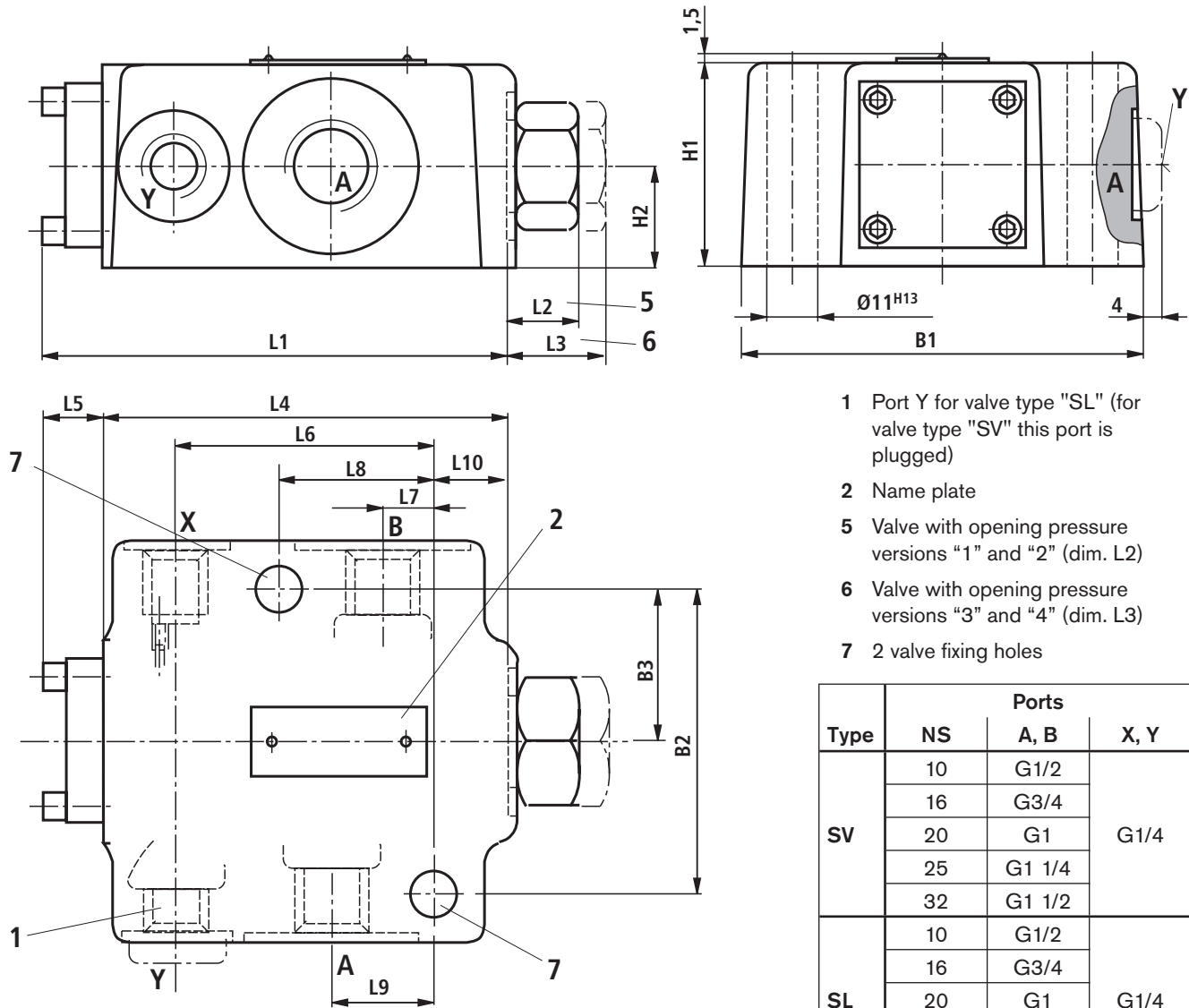

- 1 Port Y for valve type "SL" (for valve type "SV" this port is plugged)
- 2 Name plate
- 5 Valve with opening pressure versions "1" and "2" (dim. L2)
- 6 Valve with opening pressure versions "3" and "4" (dim. L3)
- 7 2 valve fixing holes

Type	Ports		
	NS	A, B	X, Y
SV	10	G1/2	G1/4
	16	G3/4	
	20	G1	
	25	G1 1/4	
	32	G1 1/2	
SL	10	G1/2	G1/4
	16	G3/4	
	20	G1	
	25	G1 1/4	
	32	G1 1/2	

Type	NS	L1	L2	L3	L4	L5	L6	L7	L8	L9	L10	B1	B2	B3	H1	H2
SV	10	100,8	15,5	15,5	87,8	13	56,5	10,5	33,5	22,5	17,3	87	66,7	33,4	44	22
	16, 20	133	17,7	47,7	115	18	74,5	17	50,5	36	27	105	79,4	39,7	68	34
	25, 32	156,1	35,7	45,7	134	22,1	101	24	84	49	18	130	96,8	48,4	85	42,5
SL	10	100,8	15,5	15,5	87,8	13	56,5	10,5	33,5	22,5	17,3	87	66,7	33,4	44	22
	16, 20	133	17,7	47,7	115	18	74,5	17	50,5	36	27	105	79,4	39,7	68	34
	25, 32	156,1	35,7	45,7	134	22,1	101	24	84	49	18	130	96,8	48,4	85	42,5

Bosch Rexroth AG
 Hydraulics
 Zum Eisengießer 1
 97816 Lohr am Main, Germany
 Telefon +49 (0) 93 52 / 18-0
 Telefax +49 (0) 93 52 / 18-23 58
 documentation@boschrexroth.de
 www.boschrexroth.de

© This document, as well as the data, specifications and other informations set forth in it, are the exclusive property of Bosch Rexroth AG. Without their consent it may not be reproduced or given to third parties. The data specified above only serves to describe the product. No statements concerning a certain condition or suitability for a certain application can be derived from our information. The details stated do not release you from the responsibility for carrying out your own assessment and verification. It must be remembered that our products are subject to a natural process of wear and ageing.